

924H

Wheel Loader

CATERPILLAR®



Cat® C6.6 Engine with ACERT™ Technology

Max. Gross Power 105 kW/143 hp

Weight

Operating Weight 11 730 kg

Buckets

Bucket Capacity 1.8-2.8 m³

924H Features

Loader Linkage

Cat exclusive VersaLink™ Loader Linkage delivers strength and versatility to help you do more tasks, faster. The high lift linkage option takes you places others can't reach.

High Performance Power Train

Designed and manufactured by Caterpillar to allow superior power and durability.

Powerful Hydraulic System

System senses work demand and adjusts flow and pressure to match for precise, efficient control.

Comfortable Cab

Large, spacious cab and low-effort, ergonomic joystick controls let you concentrate on your work.

Work Tools

Make your 924H the most versatile machine on the jobsite with Caterpillar's broad range of work tools.



Contents

VersaLink Loader Linkage	3
Power Train	4
Hydraulics	5
Operator Station	6
Work Tools	7
Serviceability	8
Customer Support	8
Specifications	9
Standard and Optional Equipment	15

The Cat® 924H Wheel Loader leads the industry in operator comfort, performance and versatility. Size, power, performance and work tool interchangeability make this machine ideal for a wide range of jobs. Fast cycle times help you move more material. Large spacious cab with joystick control keeps you comfortable throughout the work day, allowing you to get more done. Loader design delivers strength and durability with superior control and unmatched versatility. Discover how much more you can get done with the new 924H.

VersaLink™ Loader Linkage

Loader design delivers unmatched versatility.

Linkage Design

The Cat exclusive VersaLink™ design provides toolcarrier controllability, versatility and parallel lift with the strength, durability and speed of Z-Bar linkage. The 924H can be configured in several ways:

- Equipped with a Quick Coupler for quick and easy work tool changes providing optimum utility and versatility.
- Equipped with pin-on work tools, such as a bucket, for a dedicated wheel loader application with exceptional breakout force, tipping load and dump height.
- Equipped with the High Lift VersaLink loader linkage option for special applications that require more reach and lift height.

Loader Performance

The VersaLink loader linkage is designed for exceptional loader performance in a wide range of applications, offering:

- Simultaneous tilt, lift and auxiliary hydraulics function for precise control of the work tool.
- Increased breakout force to shorten cycle times and increase bucket fill factors.
- Higher dump clearance for working in “high target” situations that ordinary loaders cannot.
- More dig depth for better excavation performance, even when equipped with larger tires.
- Greater rackback angle for improved material retention, resulting in higher productivity.
- Greater dozing angle for improved control of material when fine grading.

Parallel Lift

Parallel lift simplifies working with palletized or stacked material. Operators can concentrate on material placement while the load automatically remains parallel throughout the lift range. And, like a toolcarrier, the 924H can easily manipulate loads at all heights.

High Lift Version

Special applications call for special equipment. The optional High Lift VersaLink loader linkage provides an additional clearance of 507 mm and is ideal for jobs that require higher lift of lighter materials. The high lift VersaLink is available in both pin-on and quick coupler versions.





Power Train

Delivers maximum rimpull to the ground and full power to loader hydraulics.

Cat Engine

The Cat C6.6 engine provides cleaner, quieter operation while delivering superior performance and durability. The 97 kW (132 hp) rated net power engine meets all worldwide emissions standards and features: flatter power curve for outstanding response in the working RPM range and patented ACERT™ Technology combined with common rail fuel system, smart waste gate turbocharger and crossflow head design for reduced emissions.

Cat Axles

Heavy-duty axles feature hardened gears and bearings for durable performance. Rear axle oscillates up to 12 degrees to help assure four-wheel ground contact for optimum traction and stability. Standard full locking front axle differentials enable outstanding traction in poor underfoot conditions. Rear axle limited slip differentials also available as an option.

Cat Transmission

Rugged Cat transmission uses heavy-duty components for durable and reliable operation. The operator can choose between manual shift and two autoshift modes, Performance or Economy. Performance mode provides maximum acceleration while the economy mode increases fuel economy and improves operator comfort.

Hydraulics

High efficiency and performance with low effort and precise control.



Load-Sensing Hydraulics

Modular hydraulic system delivers precise control with low effort operation. This load-sensing, variable flow system senses work demand and adjusts flow and pressure to match. This allows full hydraulic forces at any engine speed for delicate jobs in tight areas. Combined with the VersaLink linkage, the hydraulic system allows simultaneous lift, tilt and auxiliary hydraulic function.



Auxiliary Hydraulics

Auxiliary hydraulics provide unparalleled versatility allowing you to select the configuration that best suits your application. Third function only or packaged with fourth enables the use of almost all work tools.



Optional Joystick with Integrated Third Function Controls

Low effort, ergonomic joystick controls provide easy operation of lift and tilt functions. The standard joystick features an integrated directional control switch for added convenience. The operator programmable transmission neutralizer can be set in seconds optimizing brake effort for all applications.

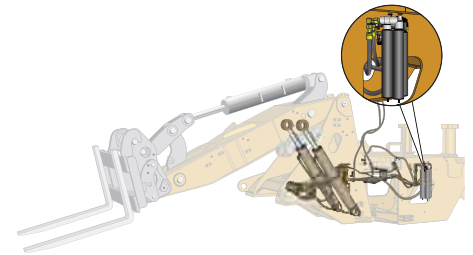

Ride Control System

The optional Ride Control System provides a comfortable ride and excellent material retention.

Four nitrogen charged accumulators set to different pressures enable optimum cushioning over uneven terrain for all loads and speeds.

The system operates in Automatic; as the loader ground speed exceeds 5 km/h the system will activate, below 5 km/h the system is off, providing maximum lift power.



Operator Station

Superior comfort keeps you productive, all day long.

Experience comfort and convenience in the H-Series cab. The spacious interior and ergonomic controls keep you comfortable throughout the work day. Choose the seat that meets your needs – the standard, fully adjustable seat or the optional Cat Contour seat for added adjustment and air suspension. The two-door design lets you enter and exit from either side of the machine and wide, serrated steps provide stable footing. Both doors lock open 180 degrees and feature sliding glass windows for better communication with workers on the ground. Large flat glass windows provide excellent visibility all around the machine. The rear window features a standard electric defroster.

Controls

Low effort, ergonomic joystick controls provide easy operation of lift and tilt functions. The standard joystick features an integrated directional control switch for added convenience. The operator programmable transmission neutralizer can be set in seconds optimizing brake effort for all applications.

Instrument Panel

The sealed instrument panel with easy to read white faced gauges and indicators keeps the operator informed of system conditions. The large LED readout provides ground speed and other critical information.

Optional Rear View Camera

This work area visual enhancement system uses a closed circuit video monitoring system. Up to three cameras can be mounted on the machine frame. Objects can be viewed on a color LCD monitor in the cab.

Work Tools

Do more jobs with one machine with Cat Work Tools.

The Right Tool for the Job

The wide variety of work tools offered by Caterpillar makes the 924H one of the most versatile machines on the jobsite. Work tools can be changed quickly and easily with the machine's quick coupler system. A switch in the cab activates a hydraulic cylinder for positive tool engagement and disengagement.

Bucket Work

With exceptional rimpull and high breakout and lift forces, the 924H delivers strong performance as a bucket loading machine. A wide range of Cat buckets are available including:

- General purpose
- Penetration
- Light material
- Multi purpose

Material Handling

The exceptional visibility and heavy-lift capabilities of the 924H let you work quickly and efficiently in material handling applications. A wide range of tools are available:

- Standard width carriage with pallet forks – various lengths available
- 2440 mm wide carriage with various lengths available
- Offset forks for improved tip visibility
- Material handling arm

Special Applications

Caterpillar also offers other work tools designed to meet specific job requirements:

- Hydraulic brooms



Serviceability

Easy access and minimal maintenance requirements keep your machine on the job.



Convenient service features make maintenance easy

All service points are accessible from ground level on the right side of the engine. Gull-wing doors with gas struts lift for exceptional access to filters and service points. Extended service intervals reduce service time and increase machine availability.

- Sight gauges let you easily check radiator coolant, hydraulic oil and transmission oil levels as well as engine air filter restriction.
- Standard pressure taps allow quick diagnosis of the entire hydraulic system.
- S•O•SSM ports make oil sampling quicker, cleaner and provide the best oil sample for analysis.
- Spin-on filters for engine oil, transmission oil and hydraulic oil are vertically mounted for easier servicing.
- Features a standard electronic fuel prime pump.
- Sequentially placed radiator and oil coolers are easy to access.
- Swing-out cooling fan allows quick and easy cleaning and servicing of the radiator. The fan is hydraulically driven and separate from the engine compartment for low noise operation.
- Optional reversing fan cleans screens without interrupting machine operation.

Customer Support

Unmatched support makes the difference

Your Cat dealer is ready to assist you with your purchase decision and everything after.

- Make comparisons of machines, with estimates of component life, preventative maintenance and cost of production.
- Financing packages are flexible to meet your needs.
- Your Cat dealer can evaluate the cost to repair, rebuild and replace your machine, so you can make the right choice.
- For more information on Cat products, dealer services and industry solutions, visit us at www.cat.com.



924H Wheel Loader Specifications

Engine

Model: Cat® C6.6 ACERT™, 6 cylinder, turbocharged, direct injection, 2300 rpm rated speed

Rated Power

Net: ISO 9249 and 80/1269/EEC	97/132 kW/hp
Gross: ISO 14396	98/133 kW/hp

Max. Power

Net: ISO 9249 and 80/1269/EEC	104/141 kW/hp
Gross: ISO 14396 and SAE J1995	105/143 kW/hp

Peak torque

Net: ISO 9249 and 80/1269/EEC	668 Nm
Gross: ISO 14396	672 Nm

Bore 105 mm

Stroke 127 mm

Displacement 6.6 L

- Net Power ratings are tested at the reference conditions for the specified standard.
- Net power shown is the power available at the flywheel when the engine is equipped with alternator, air cleaner, muffler and fan at minimum speed.
- No derating required up to 3000 m altitude. Auto derate protects hydraulic and transmission systems.
- The Caterpillar® C6.6 engine meets Stage III off-highway emission regulations.

Buckets

Bucket capacities 1.8-2.8 m³

Weight

Operating weight 11 730 kg

- Specifications shown are for 924H with optional counterweight, standard lubricants, full fuel tank, deluxe cab, Limited Slip rear axle with heavy duty brakes, additional guarding, 2.1 m³ bucket with bolt-on cutting edge, 80 kg operator and 20.5 R 25 radial (L-3) XHA tires and quick couplers.

Steering

Steering articulation 40°

Minimum turning radius (over tire) 5070 mm

Steering angle, each direction 40°

Steering cylinders, two, bore 70 mm

Hydraulic output at 2300 engine rpm and 69 bar 106 L/min

Maximum working pressure 207 bar

Loader Hydraulic System

Output at 2300 engine rpm and 69 bar with SAE 10 W oil at 65° C 152 L/min

Hydraulic cycle time 8.9 Seconds

Pump flow – implement pump 152 L/min

Relief pressure – implement pump 259 bar

Maximum working pressure 259 bar

Hydraulic cycle time Seconds

Raise 5.1

Dump 1.4

Lower, empty, float down 2.4

Total 8.9

Lift cylinders, double acting:

Bore 101.6 mm

Stroke 810 mm

Tilt cylinder, double acting:

Bore 133.4 mm

Stroke 945 mm

Service Refill Capacities

	liter
Fuel tank	225
Cooling system	40
Crankcase	15
Transmission	23
Differentials and final drives:	
Front	21
Rear	21
Hydraulic system (including tank)	148
Hydraulic tank	70

Engine Torque

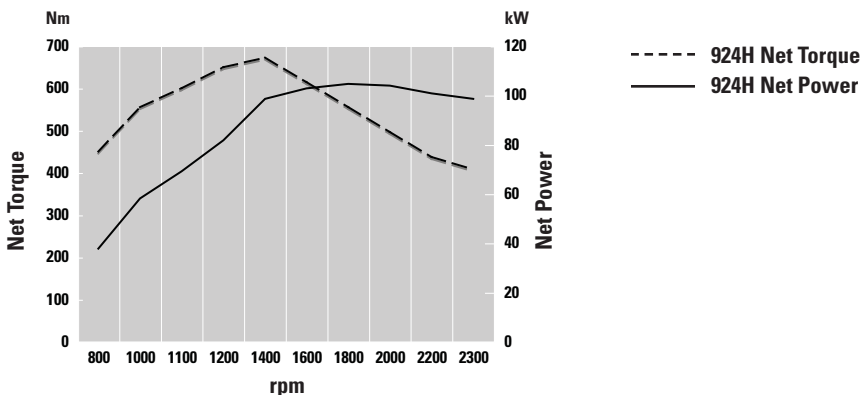

924H Wheel Loader Specifications

Transmission

	km/h
Standard transmission max travel speeds	39
Forward	
1	7
2	12
3	22
4	39
Reverse	
1	7
2	12
3	22
Optional low speed transmission max travel speeds	39
Forward	
1	4
2	8
3	20
4	39
Reverse	
1	4
2	8
3	21

Tires

Size	20.5 R 25 (L-3)
Tread width	1880 mm
• Choice of:	
	17.5–25, 12 PR (L-2)
	17.5–25, 12 PR (L-3)
	17.5 R 25 (L-2)
	17.5 R 25 (L-3)
	20.5–25, 12 PR (L-2)
	20.5–25, 12 PR (L-3)
	20.5 R 25 (L-2/L-3)
• Other tire choices are available, contact your Cat® Dealer for details.	
• In certain applications, the loader's productive capabilities may exceed the tire's tonnes-km/h (ton-mph) capabilities. Caterpillar recommends that you consult a tire supplier to evaluate all conditions before selecting a tire model.	

ROPS/FOPS

- Caterpillar cab with integrated Rollover Protective Structure (ROPS/FOPS) are standard.
- ROPS meets ISO 3471:1994.
- FOPS meets ISO 3449:1992 Level II.

Sound

Operator Sound

The operator sound level measured according to the procedures specified in ISO 6394:1992 is 74 dB(A), for cab offered by Caterpillar, with doors and windows closed.

Exterior Sound

As manufactured by Caterpillar, this machine's exterior sound power level meets the criteria spelled out in the European Directives noted on the certificate of conformance and the accompanying labeling.

- Standard version 104 dB(A)
- Low sound or Blue Angel version 101 dB(A)

Operating Specifications

Static tipping load (full turn)	7276 kg
Reach – full lift/	
45 degree dump angle	992 mm
Dump clearance – full lift/	
45 degree dump angle	2828 mm
Articulation angle (each side)	40°

Dimensions

All dimensions are approximate.

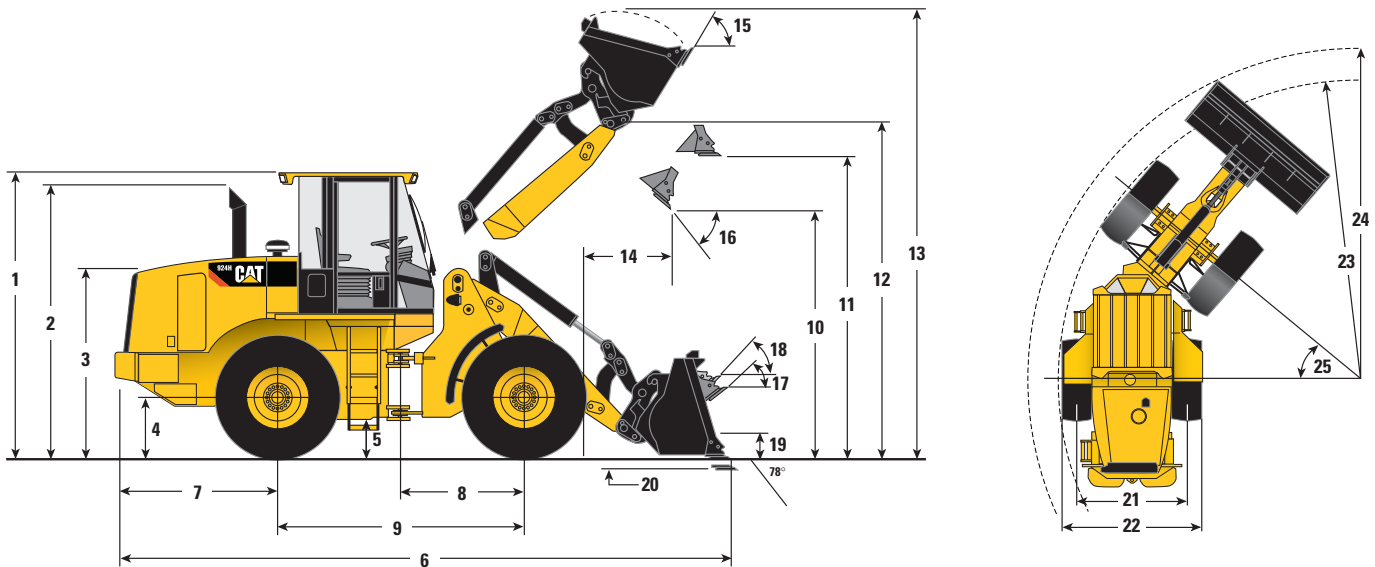

	Standard VersaLink	High Lift VersaLink
1 Height to top of ROPS/FOPS	3227 mm	3226 mm
2 Height to top of exhaust stack	3211 mm	3210 mm
3 Height to top of hood	2219 mm	2218 mm
4 Height to centre of axle	692 mm	692 mm
5 Ground clearance	436 mm	435 mm
6 Overall length	7147 mm	7649 mm
7 Length - rear axle to bumper	1962 mm	1962 mm
8 Centre line of front axle to hitch	1400 mm	1400 mm
9 Wheel base length	2800 mm	2800 mm
10 Dump clearance at maximum lift and 45° dump angle	2828 mm	3335 mm
11 Bucket clearance at maximum lift and carry	3556 mm	4063 mm
12 Bucket pin height at maximum lift	3881 mm	4387 mm
13 Overall height - bucket raised	5178 mm	5684 mm
14 Reach at maximum lift and 45° dump angle	992 mm	993 mm
15 Rack back angle at maximum lift and level	58°	62°
16 Dump angle at maximum lift	45°	45°
17 Rack back angle at ground	50°	50°
18 Rack back angle at carry	51°	54°
19 Carry height	435 mm	592 mm
20 Digging depth	64 mm	75 mm
	17.5-25 12 PR (L-2) Tires	20.5 R 25 L-3 XHA Tires
21 Width over tread center	1880 mm	1880 mm
22 Overall width over tires	2356 mm	2492 mm
23 Minimum turning radius over tires	5070 mm	5104 mm
24 Loader clearance radius with bucket in carry position	5675 mm	5633 mm
25 Steering angle - left/right	40°	40°
Change in vertical dimension	-44 mm	0

Dimensions listed are for 924H with 1.8 m³ coupler bucket with bolt-on cutting edge, standard cab, optional counterweight, limited slip axles, heavy duty rear brakes, additional guarding, sound suppression, 80 kg operator and Michelin 20.5 R 25 L3 XHA tires.

924H Wheel Loader Specifications

Dimensions with Pallet Forks

All dimensions are approximate. Dimensions may vary with fork length.

Standard VersaLink Fork Tine Length

	mm	mm	mm
	1220	1370	1524
1	7604	7769	7908
2	-33	-33	-33
3	871	886	871
4	1562	1577	1562
5	3637	3652	3637
6	1790	1805	1790
7	762	777	762

High Lift VersaLink

	mm	mm	mm
1	8113	8278	8417
2	-43	-43	-43
3	1379	1394	1379
4	1953	1968	1953
5	4145	4160	4145
6	1790	1805	1790
7	762	777	762

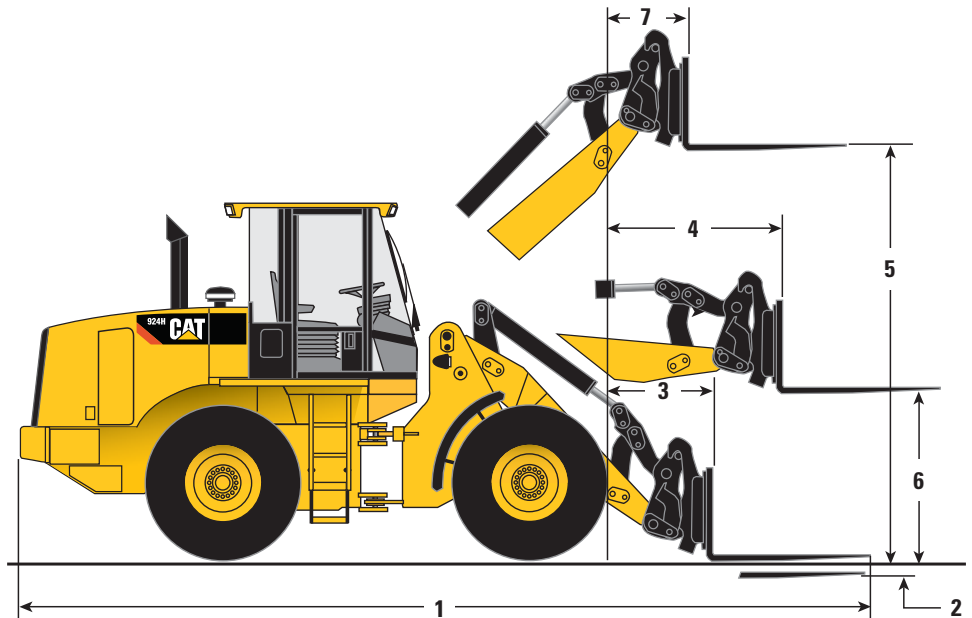

Operating Specifications with Pallet Forks

	Fork Tine Length 1220 mm	Fork Tine Length 1370 mm	Fork Tine Length 1524 mm
Standard VersaLink:			
Operating load:			
Per EN 474-3, rough terrain (60% of FTSTL)	3279 kg	3230 kg	3225 kg
Per EN 474-3, firm and level ground (80% of FTSTL)	4372 kg	4306 kg	4300 kg
Load center	600 mm	600 mm	600 mm
Static tipping load with level arms and forks, straight*	6200 kg	5962 kg	5808 kg
Static tipping load with level arms and forks, full 40° turn*	5447 kg	5231 kg	5091 kg
Operating weight*	11 209 kg	11 268 kg	11 298 kg
High Lift VersaLink:			
Operating load:			
Per EN 474-3, rough terrain (60% of FTSTL)	2803 kg	2758 kg	2749 kg
Per EN 474-3, firm & level ground (80% of FTSTL)	3738 kg	3677 kg	3666 kg
Load center	600 mm	600 mm	600 mm
Static tipping load with level arms and forks, straight*	5322 kg	5128 kg	5003 kg
Static tipping load with level arms and forks, full 40° turn*	4658 kg	4481 kg	4367 kg
Operating weight*	11 327 kg	11 386 kg	11 417 kg

* Static tipping and operating weights shown are for 924H with 1.8 m³ coupler bucket with bolt-on cutting edge, standard cab, optional counterweight, limited slip axles, heavy duty rear brakes, additional guarding, sound suppression, 80 kg operator and Michelin 20.5 R 25 L-3 XHA tires. Tipping load is defined by SAEJ732 JUN92.

Loader Linkage

Operating specifications with bucket

		Coupler Buckets Bolt-On Cutting Edge						Pin-On Buckets Bolt-On Cutting Edge					
		Standard			High Lift			Standard			High Lift		
Rated bucket capacity *	m ³	1.8	2.1	2.8	1.8	2.1	2.8	1.8	2.1	2.8	1.8	2.1	2.8
Struck capacity *	m ³	1.5	1.7	2.3	1.5	1.7	2.3	1.5	1.7	2.3	1.5	1.7	2.3
Bucket width	mm	2550	2550	2550	2550	2550	2550	2550	2550	2550	2550	2550	2550
10 Dump clearance at full lift and 45° discharge *	mm	2828	2665	2621	3335	3173	3129	2918	2849	2712	3426	3357	3220
14 Reach at full lift and 45° discharge *	mm	992	924	1197	992	924	1197	885	957	1093	885	957	1093
Reach at 45° discharge and 2130 mm clearance *	mm	1516	1358	1603	1947	1804	2054	1453	1491	1554	1877	1920	1995
Reach with lift arms horizontal and bucket level	mm	2296	2386	2586	2686	2776	2976	2156	2255	2448	2546	2645	2838
20 Digging depth *	mm	64	121	89	74	131	99	64	70	87	74	80	97
6 Overall length	mm	7147	7288	7460	7649	7779	7957	7007	7112	7320	7506	7613	7818
13 Overall height with bucket at full raise *	mm	5067	5135	5328	5574	5643	5836	4966	5095	5152	5473	5603	5660
24 Loader clearance radius with bucket in carry position *	mm	5568	5610	5658	5828	5877	5931	5530	5558	5616	5785	5818	5885
Static tipping load, straight *	kg	8310	7793	7871	6789	6359	6410	8738	8557	8272	7120	6954	6718
Static tipping load, full 40° turn *	kg	7276	6792	6859	5916	5509	5552	7666	7490	7222	6219	6056	5833
Breakout force *	kN	97	89	76	97	89	76	111	100	85	111	100	85
Operating weight	kg	11 501	11 734	11 744	11 620	11 852	11 863	11 379	11 515	11 638	11 498	11 633	11 757

Static tipping and operating weights shown are for 924H with cab with A/C, optional counterweight, limited slip axles, heavy duty rear brakes, additional guarding, sound suppression, work tool, 80 kg operator and Michelin 20.5 R 25 L-3 XHA tires.

* Specifications and ratings conform to all applicable standards recommended by the Society of Automotive Engineers (SAE), including SAE-Standards J732 JUN92 and J742 FEB85 governing ratings.

Other Ground Engaging Tools available, consult your Cat dealer.

924H Wheel Loader Specifications

Supplemental Specifications

	Change in Operating Weight	Change in Articulated Static Tipping Load with Hook-On Bucket 1.8 m ³
	kg	kg
Canopy, ROPS (less cab)	-199	-166
Counterweight, 175 kg (removal)	-175	-273
Guard, crankcase	-15	-19
Guard, driveshaft	-17	-5
Guard, power train	-52	-47
Ride Control System	-40	-27
Secondary steering (removal)	-37	-31
Tires, 1 piece rims		
17.5-25, 12PR (L-2)	-652	-371
17.5-25, 12PR (L-3)	-580	-330
17.5-R25, radial (L-2)	-612	-348
17.5 R25, radial (L-3)	-512	-292
Tires, 3 piece rims		
17.5-25, 12PR (L-2)	-528	-301
17.5-25, 12PR (L-3)	-456	-260
17.5-25, radial (L-2)	-488	-278
17.5 R25, radial (L-3)	-388	-221
20.5-25, 12PR (L-2)	-240	-137
20.5-25, 12PR (L-3)	-36	-21
20.5-25, radial (L-2)	-172	-98
20.5-25, radial (L-3)	0	0

Typical Material Densities – Loose

	kg/m ³
Basalt	1960
Bauxite, Kaolin	1420
Clay	
natural bed	1660
dry	1480
wet	1660
Clay and gravel	
dry	1420
wet	1540
Decomposed rock	
75% rock, 25% earth	1960
50% rock, 50% earth	1720
25% rock, 75% earth	1570
Earth	
dry, packed	1510
wet, excavated	1600
Granite	
broken	1660
Gravel	
pitrun	1930
dry	1510
dry, 6-50 mm	1690
wet, 6-50 mm	2020
Gypsum	
broken	1810
crushed	1600
Limestone	
broken	1540
crushed	1540
Sand	
dry, loose	1420
damp	1690
wet	1840
Sand and clay	
loose	1600
Sand and gravel	
dry	1720
wet	2020
Sandstone	1510
Shale	1250
Slag	
broken	1750
Stone	
crushed	1600
Wood chips	400

Typical Material Densities – Loose

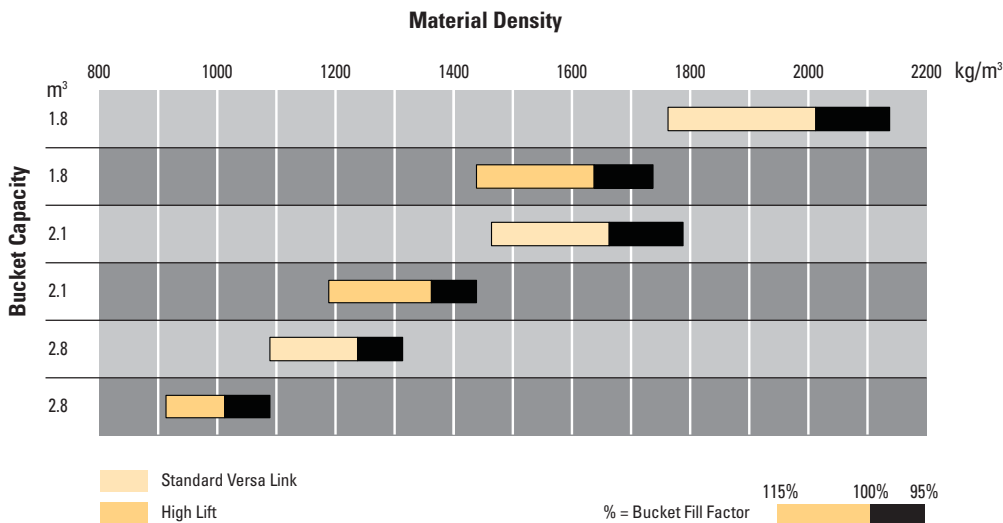

Standard equipment may vary. Consult your Caterpillar dealer for details.

ELECTRICAL

Alternator, 95 A brushless
Alarm, back-up
Batteries, maintenance-free, 950 CCA, (2)
Directional signals (front & rear)
Non Rooding Lights
Starting and charging system, 24V
Halogen work lights (front & rear)
Ignition key start/stop switch
Starting aid, thermal
Switch, battery disconnect

OPERATOR ENVIRONMENT

Standard two door cab includes all of the following items:
Heater/defroster
Radio ready
12 volt electrical accessory outlet
Sealed Instrument Gauge:

- Engine RPM
- Hydraulic oil temperature
- Engine coolant temperature
- Torque converter oil temperature
- Fuel level
- Digital LED speedometer, hour meter/odometer

Indicator Lights:

- Turn signal
- Primary steering malfunction
- Hydraulic oil bypass
- Parking brake applied
- Brake charge pressure low
- Transmission oil temperature
- General warning
- Electrical system voltage low
- Fuel water separator
- Engine oil temperature
- Bright lights activated

Adjustable tilt steering column
Coat hook
Ground level door release
Horn, steering wheel mounted (electric)
Hydraulic control lever lockout
Interior light
Lighter
Lunch box storage with cup holder
Pilot hydraulic implement controls
Rear window defroster, electric
Rear view mirrors (2 inside)
Seat, adjustable suspension, armrest (fabric or vinyl)
Seat belt

Tinted safety glass, front
Wet arm wiper/washer (front & rear), front intermittent

POWER TRAIN

Engine, Cat C6.6 ACERT

- Dust bowl pre cleaner
- Low emission diesel engine
- Noise reduction technology
- Smart waste gate turbocharged
- Aftercooled
- Closed Circuit Breather
- Electronically controlled

Air cleaner, dry type
Axle seal guards, integrated
Brakes, enclosed wet-disc full hydraulic
Differentials, conventional (front/rear)
Driveshaft, lubed for life
Electric fuel prime pump
Engine speed control
Fuel/water separator
Muffler
Radiator, unit serviceable
S•O•S oil sampling port, engine oil
S•O•S oil sampling port, transmission oil
Torque converter

924H Optional Equipment

Optional equipment may vary. Consult your Caterpillar dealer for details.

Antifreeze/coolant, extended-life, protects to -50° C
Axles:

- Rear, Limited Slip Differential

Beacon light, rotating or strobe, magnetic mount
Buckets/ground engaging tools
Canopy, ROPS
Counterweight, additional, optional
Deluxe Cab arrangement includes:

- External heated mirrors
- Sunscreen
- Sun shade
- Sliding Glass Door
- Flood lights, auxiliary, cab mounted

Fan, reversing
Fenders, roading, rear
Fenders, steel
Air Conditioner,
Alarm Back Up.
Roading Lights

Guards:

- Crankcase
- Driveshaft, front
- Power train
- Lights
- Windshield
- Radiator

Hydraulic control auxiliary; third, fourth, fifth and sixth valve
Integrated third function hydraulic joystick control
Linkage, high lift
Load check valves (dealer installed)
Low speed transmission
Machine Security System
Material handling arm
Pallet forks, carriage
Pallet forks, carriage, wide version
Product Link
Quick Coupler, IT style
Quick Coupler, wide
Waste Handler Packages
Speed Limiter 20 km/h
Radiator, wide fin spacing

Radio packages:

- Radio, AM/FM with CD player

Rear-view camera system
Ride Control System
Seats:

- Cat Contour Seat, fabric, with adjustable backrest and lumbar support
- Cat Contour Seat, fabric, electrically adjustable with air suspension

Sound suppression package, available in select markets
Starting aid, engine coolant heater, 120V
Steering, secondary
Tires:

- Bias ply, 17.5-25 and 20.5-25
- Radial, 17.5-R 25, 20.5-R 25 and 550/65 R 25

924H Wheel Loader

For more complete information on Cat products, dealer services, and industry solutions, visit us on the web at www.cat.com

HEHL3663 (01-2008) hr

Materials and specifications are subject to change without notice. Featured machines in photos may include additional equipment. See your Caterpillar dealer for available options.

© 2007 Caterpillar -- All rights reserved

CAT, CATERPILLAR, their respective logos, "Caterpillar Yellow" and the POWER EDGE trade dress as well as corporate and product identity used herein, are trademarks of Caterpillar and may not be used without permission.

CATERPILLAR[®]